

HOW TO OPERATE MARGARITA MACHINE

1. Press main power switch and agitator switch to ON position, see reverse for Control Functions. **NOTICE:** The agitator switch must be to ON position before setting to liquid or slush mode.
2. Switch the cooler switch to desired mode, liquid or slush.
3. Fill the mix tank with one of Special Event Rentals flavoured slush mix contents or desired liquid product (3 gallons maximum). Do not overfill the tank. **NOTICE:** If using frozen mode, slush occupies more volume than liquid (approximately 3.5 gallons of slush for 3 gallons of liquid).

TROUBLESHOOTING

PROBLEM	QUICK FIX
<i>Unit cools but does not freeze</i>	<ul style="list-style-type: none"> • Check that switch is on right position. • Remove objects that may be blocking airflow around unit.
Tap drips	<ul style="list-style-type: none"> • Check that the piston is correctly closed. • Verify that the spring works correctly.

BEFORE RETURNING

- A \$37.50 cleaning charge will apply to each margarita machine if units are not returned in the same condition they were received.
- To avoid cleaning charges, wipe all interior and exterior surface areas clean.

CONTROL FUNCTIONS

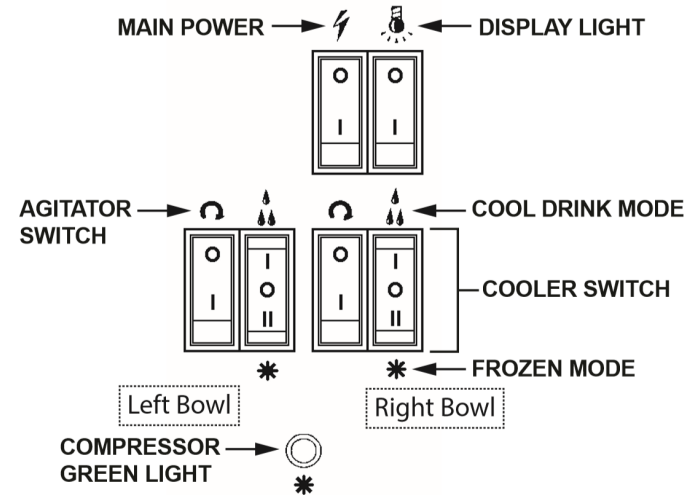

MAIN POWER

- **"0" Position:** OFF position. Power is turned off to all functions.
- **"I" Position:** ON position. Machine has power.

DISPLAY LIGHT

- **"0" Position:** Lights are OFF.
- **"I" Position:** Lights are ON. Display lights have power.

AGITATOR SWITCH

- **"0" Position:** Agitator is OFF.
- **"I" Position:** Agitator is ON.

COOLER SWITCH

- **"0" Position:** OFF position.
- **"I" Position:** Cool drink mode.
- **"II" Position:** Frozen mode.

COMPRESSOR GREEN LIGHT

- If the compressor green light is on, the compressor should be working.